



► **KSL100ARC**
弧光保护系统



克斯勒电气



公司简介

COMPANY INTRODUCTION

克斯勒电气是中外合资企业，是致力于电力、能源、工矿等领域内用电安全、电能质量提升、能效管理的专业化公司。产品和方案涉及光电传感设备及其自动化系统，电能质量提升和管理系统，中低压输配电设备等。在光电传感智能化领域，我们具备行业的前瞻性和开拓理念，在国外，我们是NGG、SSE等能源公司的重要供货商之一。

专注于新能源和电力行业的发展，对市场反馈的专业和长期的调研，不断的完善自身产品、方案的性能及优越性，让我们同步于世界一流水平的技术服务于每个客户。根据每个用户的实际工况，可定制高效、可靠的各种器件及成熟稳定的方案。



我们为您：

能效管理企业
输变电企业
工矿企业
智能楼宇
轨道交通
提供可以信赖的技术和服务

We provide to

Energy efficiency management enterprises
Transmission and distribution enterprises
Industrial and mining enterprises
Intelligent buildings
Rail transportation
with reliable technologies and services

全球最先进的检验检测设备、完善的生产管理流程控制，确保每个出厂产品的质量和精度，持续创新的解决方案的研发，为推动社会进步贡献重要力量。

领导关怀

Leader's Care



中共南京市委书记黄莉新视察我司



南京市副市长储永宏视察我司



南京经济技术开发区管委会主任高德臣视察我司

典型业绩

Typical performance

石油化工:

中石化金陵石化、哈萨克斯坦PK炼厂、中海油J9-3埕北平、金山石化、辽河油田、燕山石化

数据中心:

湖南益阳芙蓉云计算中心项目220kv变电站总承包工程、中国移动廊坊数据中心、中国移动南京数据中心、贵阳电信金阳枢纽、腾讯北京数据中心

电网、电厂:

国家电网公司&南方电网公司所辖的，江苏省电力公司、浙江省电力公司、山东省电力公司、重庆市电力公司、福建省电力公司、湖北省电力公司、新疆区电力公司、云南省电力公司、贵州省电力公司等，华能集团、华电集团、中电投集团、华润电力、国华电力、神华集团等。

机场、轨道交通:

哈尔滨太平机场、宁波栎社机场、武汉天河机场、南京禄口机场、长治机场、梅县机场、哈尔滨至牡丹江铁路电气化改造工程、通让铁路项目、上海地铁虹桥枢纽工程

新能源:

力神电池（苏州）产业园、江西海能新能源储能产业园、滁州动力电池基地、江苏耀宁新能源产业园、吉利宁国动力电池产业园

医疗、公共设施:

江苏省人民医院、扬子江隧道、青奥五台山体育馆、瑞金医院、北京301医院、江苏广电中心

- **弧光简介 ArcLight Introduction**
 - 概述 Summary
 - 电弧光产生的原因 The Causes of electric Arc Light
 - 电弧光的危害 Harm of electric arc light
 - 目前用于中、低压母线的保护现状
 - The Current Status of Protection for Medium and Low-Voltage Busbars
- **人体触电分析 Analysis of human body electric shock**
- **继电保护标准 Relay protection standard**
 - 配网系统完善“母线保护”的重大意义
 - The Great Significance of Improving "Bus Protection" in the Distribution Network System
 - 电力系统继电保护标准 Power system protection standard
- **弧光保护系统简介 Brief Introduction of Arc Protection System**
 - 电弧光保护 Arc light protection
- **母线弧光保护系统 KSL101ARC (H型)**
 - Medium and high voltage busbar arc protection system KSL101ARC (H)
 - 母线保护工作原理 Busbar protection works
 - 弧光保护动作时限 Arc protection action time limit
 - 系统构成 System Components
 - 母线弧光保护装置 Medium and high voltage busbar arc protection device
 - 二次原理图 Secondary schematic diagram
 - 弧光扩展单元 Arc Expansion Unit
- **馈线智能弧光保护系统 KSL101ARC (F型)**
 - Feeder intelligent arc protection system KSL101ARC (F)
 - 产品简述 Product Description
 - 系统构成 System Components
 - 馈线智能弧光保护装置 Feeder intelligent arc protection device
 - 二次原理图 Secondary schematic diagram
- **弧光传感器 KSL127ARC Arc sensor KSL127ARC**
 - 电弧光的发生过程 The process of arc light
 - 弧光的光学特点 The optical characteristics of the arc
 - 弧光传感器 KSL227ARC 的特点 The characteristics of the arc sensor
 - KSL227ARC 弧光传感器的应用场合 Application of arc sensor
- **安装示意图 Installation diagram**
- **弧光保护上图方式 Design drawing of arc protection**
 - 母线弧光保护系统 KSL101ARC (H型) 及馈线智能弧光保护系统 KSL101ARC (F型) 上图方式
 - The Diagramming Method for the Busbar Arc Protection System KSL101ARC (Type H) and the Feeder Intelligent Arc Protection System KSL101ARC (Type F)

弧光简介

Arc Light Introduction

■ 概述

Summary

在我国，中、低压母线短路故障中，重点设备和人员伤害主要由电弧光引起，然而，我国的大多数中低压母线没有设置快速母线保护，而只是采用了简单的消弧装置和变压器后备保护。这些保护智能化较低，动作速度慢，往往会延长故障切除时间，从而进一步扩大设备损坏程度，甚至会引起“火烧连营”的恶性事故，冲击变压器一次运行，影响整个电网的安全运行。

In China, in the short circuit fault of medium and low voltage bus, the key equipment and personnel injuries are mainly caused by the arc light, however, most of the medium and low voltage bus in China do not set up fast bus protection, but only use a simple arc suppression device and transformer backup protection. These protection is low intelligence, slow operation speed, often prolong the fault removal time, thus further expanding the extent of equipment damage, and even cause "fire" malignant accidents, impact transformer operation, affecting the safe operation of the entire power grid.

■ 电弧光产生的原因

The Causes Of Electric Arc Light

人为原因有

- 误入带电间隔
Blunder into Charged Interval unit.
- 隔离开关误操作
Misoperation isolating switch.
- 带接地线合闸
Closing with grounding wire.
- 忘记测量工作区内的电压等
Forget the voltage measurement in the work area.

技术原因有

- 设备故障和带电设备的误操作
Misoperation of device fault and charged equipment.
- 设备正常检修后，遗漏工具在开关设备内
Missing tools in the switchgears.
- 错误的接线和母线连接
Wrong wiring and busbar connection.
- 绝缘老化、机械磨损、过电压、小动物（尤其是老鼠）、
灰尘、温度、湿度及腐蚀等环境因素
Insulation aging, mechanical wear, over voltage, small animals (especially the mouse), dust, temperature, humidity and corrosion and other environmental factors.



■ 电弧光的危害 Harm Of Electric Arc Light

○开关柜内发生短路弧光的功率可高达100MW，电弧燃烧所产生的能量与电弧的燃烧时间及短路电流变化值呈指数倍增长（如下图所示），燃烧产生的高温、高压将会逐步摧毁元器件、铜排以及成列的开关柜，高明亮的弧光和有毒气体对人体也有巨大的伤害。

The power of the short-circuit arc in the switch cabinet can be as high as 100MW, the energy generated by arc combustion and the change value of the arc burning time and short-circuit current increase exponentially (as shown in the figure below), the high temperature and high pressure generated by combustion will gradually destroy the components, copper bars and columns of the switch cabinet, and the bright arc light and toxic gases also have great harm to the human body.

○电缆熔毁，电缆护套着火；

Cable meltdown, cable sheath fire.

○过热导致压力上升，使开关设备爆炸；

Overheating pressures rise, make the switch equipment explosion.

○开关设备剧烈振动，使固定元件松脱；

Severe vibration switch equipment, so that the fixed component loosening.

○使上一级变压器承受近距离短路故障冲击，故障电流产生的电动力可能导致变压器绕组变形发生匝间短路；

Make a transformer under close short circuit fault impact, the fault current of electric power may lead to the occurrence of inter turn short circuit of transformer winding deformation.

○故障产生的弧光冲击波以300m/s的速度爆发，可摧毁途中的任何物质，若波及站内直流系统造成全站直流失电，将造成无法弥补的重大损失；

When the shock wave produced by the arc fault outbreaks at a speed of 300m/s, any material can be destroyed. If the Station DC system is affected, causing power loss at the whole station, it will cause great loss.

○高温灼伤皮肤，强光刺伤眼睛；

The high temperature burns the skin, and bright lights causes eye injuries.

○爆破音振损伤耳膜，肺脏；

Plosive vibration eardrum injury, lung.

○爆炸碎片四射，造成人员伤亡。

Flying explosion fragments cause a large amount of casualties.



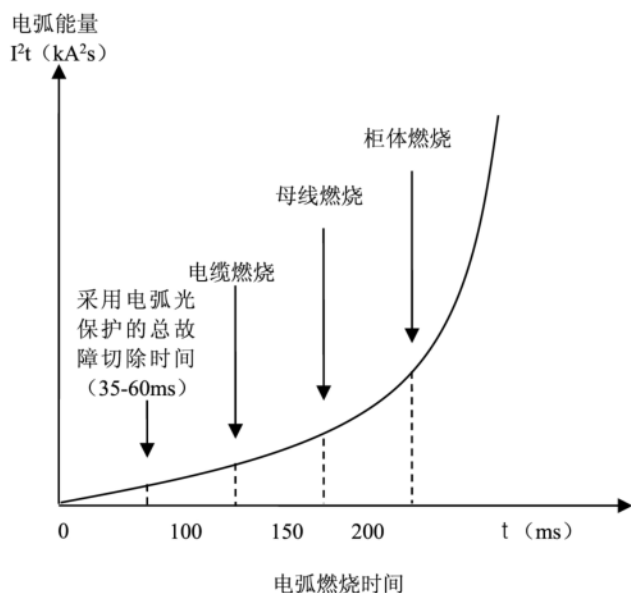

图一 电弧光的危害示意图

电弧光故障的危害程度取决于电弧光电流的大小及切除时间长短，电弧光产生的能量与切除时间 t 成指数规律快速上升（见图一）；

The damage degree of electric arc fault depends on the size of the arc current and the length of the resection time. The energy generated by arc and the clearing time T increase exponentially.

要保证设备不受结构性损伤，必须尽量缩短切除时间。

To ensure that the equipment is not affected by structural damage, We must try to shorten the clearing time .

以下为各种燃弧时间长短和对设备造成的损坏程度的评估：

燃弧时间	设备损坏程度
35 ms	没有显著的损坏，一般可以在检验绝缘电阻后投入使用
100ms	损坏较小，在开关柜再次投入运行以前需要进行清洁或某些小的修理
500ms	设备损坏很严重，在现场的人员也受到严重的伤害，必须更换部分设备才可以再投入运行。

■ 目前用于中、低压母线的保护现状

The Present Status Of Protection In Mid And Low-voltage Bus

- 变压器后备过流保护,典型的保护动作时间 0.8~1.5s

Transformer backup over-current protection, protection action time is from 0.8~1.5s

- 采用馈线速断保护闭锁的变压器后备过流保护，典型的保护动作时间为300ms ~ 500ms

Using feeder quick break protection atresia transformer backup overcurrent protection, protection action time is typically from 300ms to 500ms.

- 母线差动保护，典型的动作时间为20ms，但其保护范围受CT安装位置的限制，对开关柜设备CT质量要求高，需要CT具有专用差动线圈，且总体造价昂贵。

Bus differential protection, the typical action time is 20ms, but its protection range by the CT installation location restrictions on the switchgear equipment CT quality requirements, the need for CT with a dedicated differential coil, and the overall cost is expensive.

人体触电分析

Analysis of human body electric shock

国际上公认，触电时间与流入人体的电流之乘积如果超过30mA.S，就会发生人体触电死亡事故。

Internationally recognized, the electric shock time and the flow of electricity into the human body if more than 30mA.S, there will be human electric shock death.

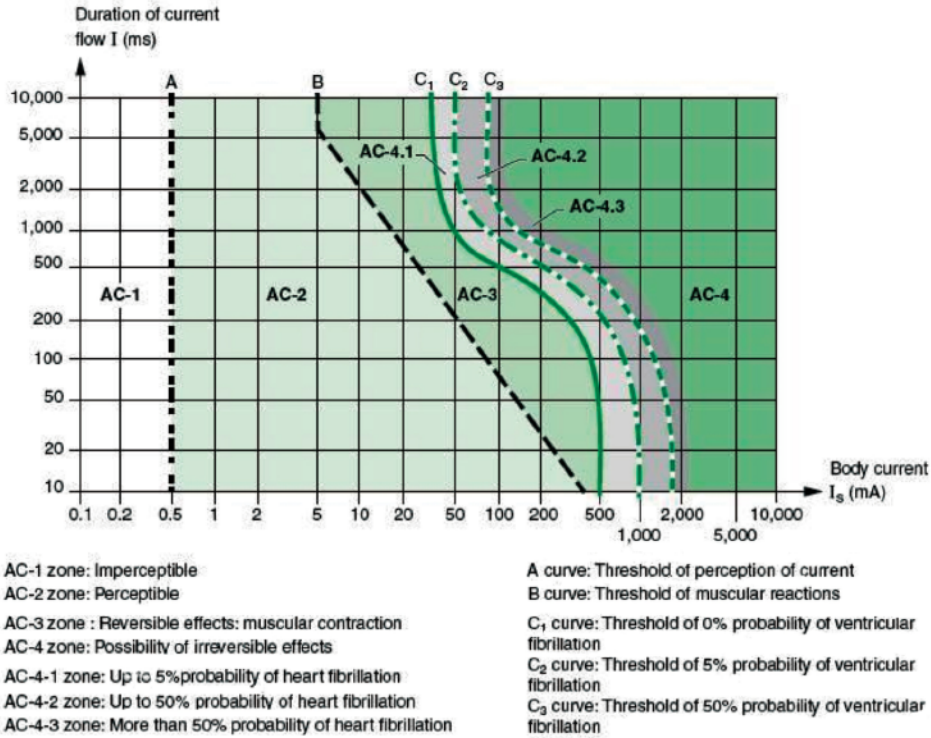

图四 IEC 经测试后得到的预期接触电压和允许最大通电时间之间的关系图

AC-1 区：通电无感觉；

AC-2 区：通电有感觉，但没有损伤；AC-3 区：通电有可能会引起一定损伤，但不会引起心室纤颤，没有生命危险；

AC-4 区：通电有可能会引起心室纤颤。其中4.1 区有 5% 的可能引起心室纤颤，4.2 区有 50% 的可能引起纤颤，4.3 区和再往右的区域，引起纤颤的概率就超过 50% 了。

AC-1 area: power without feeling;

AC-2 area: power is feeling, but no damage; AC-3 area: power may cause some damage, but will not cause ventricular fibrillation, no life risk;

AC-4 area: power may cause ventricular fibrillation. Of which 4.1% of the area may cause ventricular fibrillation, 4.2 area 50% may cause fibrillation, 4.3 area and then to the right area, causing the probability of fibrillation is more than 50%.

C1 曲线以左的区域，都是不会造成生命危险的。所以国际上将C1 曲线最上边的电流值，大约是30mA，作为一个评判是否安全的界限。

C1 curve to the left of the region, are not life-threatening. So the international C1 curve on the top of the current value, about 30mA, as a judge whether the safety limits.

人体电阻大约在2kΩ左右；皮肤出汗时，约为1kΩ左右。

Body resistance is about 2kΩ or so; skin sweating, about 1kΩ or so.

继电保护标准

Relay protection standard

■ 配网系统完善“母线保护”的重大意义

Distribution network system to improve the "bus protection" of the great significance

- 降低“电力人身伤亡事故”，对走错间隔人员受到电弧光的伤害降到最小；
Reduce the "power personal injury and death accident", the wrong interval by the arc light damage to a minimum;
- 在“带电作业”情况下最大限度的保证电力操作人员的人身安全；
In the case of "live work" to maximize the safety of the operator to ensure personal safety;
- 在“误操作”“违规操作”“错误接线”等情况下，控制事故发生范围；
In the "misuse" "illegal operation" "wrong wiring" and so on, control the scope of the accident;
- 有效减少配网故障对上级220/110kV变压器受短路冲击的时间，保护主设备；
Effectively reduce the distribution network failure on the upper 220 / 110kV transformer short circuit impact of the time to protect the main equipment;
- 快速切除相间/三相故障，避免“配网事故扩大成输电网二次事故”的发生；
Rapid removal of phase / three-phase failure, to avoid "distribution network accident into a power grid second accident" occurred;
- 快速切除单相弧光接地故障，有效缩小故障范围，避免引起相间/三相故障；
Rapid removal of single-phase arc grounding fault, effectively reduce the fault range, to avoid causing phase / three-phase failure;
- 通过弧光传感器的物理定位实现故障定位，有效查找故障点及分析故障原因；
Through the physical positioning of the arc sensor to achieve fault location, effectively find the fault point and analyze the cause of the failure;
- 目前开关柜被严重烧毁的故障率为0.1%，有效降低开关柜的损害程度和事故损失；
The current switchgear was severely burned the failure rate of 0.1%, effectively reduce the degree of damage to the switchgear and accident losses;
- 将事故引发的间接损失降到最低，缩短停电时间，及时恢复供电，提高经济效益；
The accident caused by the indirect loss to a minimum, shorten the power outage, timely recovery of power supply, improve economic efficiency;
- 有效的避免事故发生后出现“越级跳闸”“冲击主变”，提高用户的考核指标免受罚款。
Effectively avoid the accident after the occurrence of "leap leap" "impact of the main transformer" to improve the user's assessment indicators from fines.



■ 电力系统继电保护标准

Power system protection standard

- ◆ GB/T14598.8-1995 《电气继电器保护系统》
GB/T14598.8-1995 《electrical relay protection system》
- ◆ GB/T14285-2006 《继电保护和安全自动装置技术规程》
GB/T14285-2006 Technical specification for relay protection and safety automatic device
- ◆ GB/T50062-2008 《电力装置的继电保护和安全自动装置的设计规范》
GB/T50062-2008 Code for design of relay protection and safety automatic device for electric power unit
- ◆ DL/T5506-2015 《电力系统继电保护设计技术规范》
DL/T5506-2015 power system relay protection design technical specifications
- ◆ DL/T1502-2016 《厂用电继电保护整定计算导则》
DL/T1502-2016 Guidelines for the calculation of relay protection for plant applications
- ◆ GB/T31237-2014 《1000kV系统继电保护装置及安全自动装置检测技术规范》
GB/T31237-2014 1000kV system relay protection devices and safety automatic device detection technical specifications
- ◆ DL/T1501-2016 《数字化继电保护试验装置技术条件》
DL/T1501-2016 Digital relay protection test device technical conditions
- ◆ GB/T32897-2016 《智能变电站多功能保护测控一体化装置通用技术条件》
GB/T32897-2016 intelligent substation multi-function protection and control integration of general technical conditions
- ◆ GB/T32901-2016 《智能变电站继电保护通用技术条件》
GB/T32901-2016 intelligent substation relay protection general technical conditions
- ◆ GB/T14598.302-2016 《弧光保护装置技术要求》
GB/T14598.302-2016 arc protection device technical requirements
- ◆ DL/T1504-2016 《弧光保护装置通用技术条件》
DL/T1504-2016 General requirements for arc protection devices
- ◆ DL/T478-2013 《继电保护和安全自动装置通用技术条件》
DL/T 478-2013 General technical conditions for automatic devices for relay protection and safety
- ◆ GB/T 7261-2016 《继电保护和安个自动装置基本试验方法》
GB/T 7261-2016 Basic test methods for relay protection and installation of automatic devices
-



主要发布单位

中华人民共和国国家质量监督检验检疫总局
中国国家标准化管理委员会
国家能源局



弧光保护系统简介

Brief Interoduction Of Arc Protection System

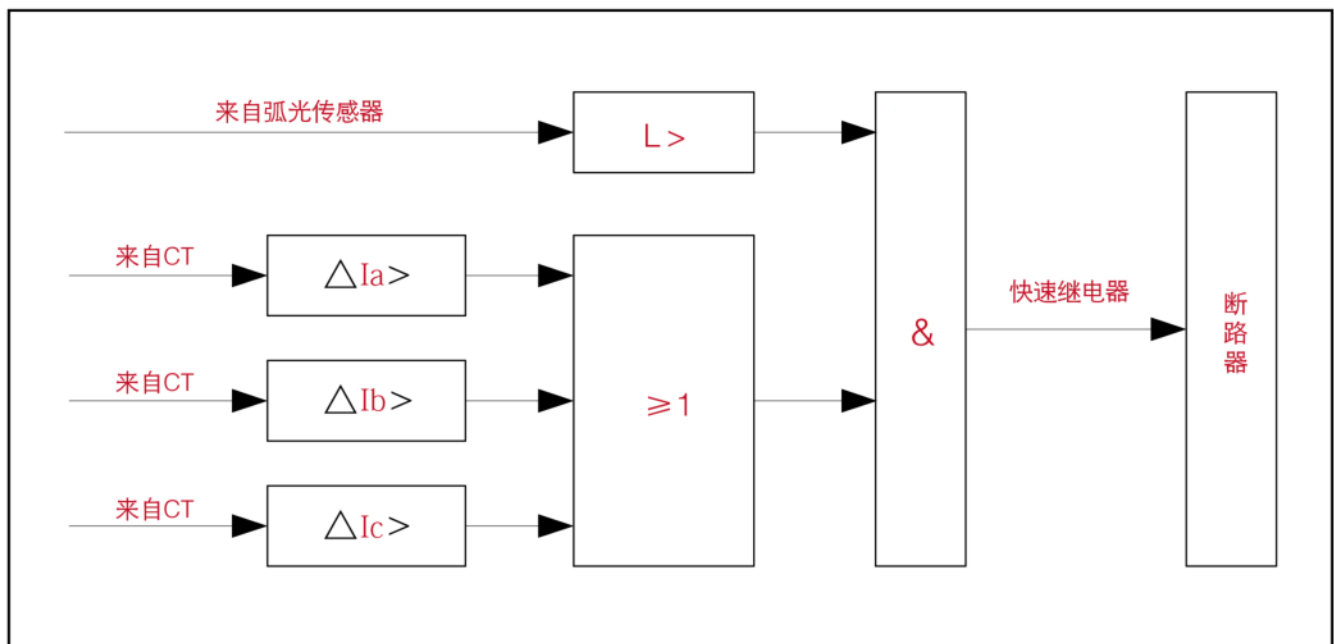

■ 电弧光保护 Arc Light Protection

电弧光保护以电流采集单元为基础分组，所有弧光探头可以整定关联到任意一组电流信号上。当弧光单元把光信号从弧光传感器传输到主控单元时，并且同时电流启动元件动作，电弧光保护动作，电流启动元件分为突变量启动元件和电流常量启动元件，两个元件取或逻辑；装置可选择弧光信号动作单判据作为动作逻辑判断。

Arc light protection with current acquisition unit based packet, All the arc probes can be setting related to an arbitrary set of current signal, When the arc unit transforms the light signal from the arc sensor is transmitted to the main control unit, And at the same time, current starting element action, Arc protection, Current start element divided into abrupt starting element and current constant starting element, The two element or logic; device can select arc signal single action criterion as the action logic judgment.



选用电弧光保护系统可以实现如下目标:

Arc Protection System Can Achieve The Following Goals:

- 减少或降低电弧光对于人体的伤害
Reduce the harm of the electric arc light to human body.
- 减少或降低电弧光短路故障对于设备的损害
Reduce the damage of electric arc light short-circuit fault to the equipment.
- 避免变压器因近距离母线故障造成动态稳定破坏，延长变压器的使用寿命
Avoid transformer for near distance bus fault caused by dynamic stability damage, prolong the service life of transformer.
- 缩短电弧光故障切除时间，避免波及站内直流系统造成重大损失
Shortening the arc fault clearing time, avoid spreading Station DC system caused significant loss.
- 减少因电弧光故障造成设备停运的时间，恢复供电
Reducing the arc fault caused by equipment outage time, recovery of power supply.

母线弧光保护系统KSL101ARC (H型)

Medium and busbar arc protection system KSL101ARC(H)

■ 母线保护工作原理

The working principle of bus protection

弧光保护系统 Arc protection system

是一个模块化系统，包括主控单元、电流单元、弧光扩展单元（可选）、弧光继电器，系统构成示意图如下图所示：

It is a modular system, including the main control unit, current unit, arc extension unit (optional), arc relay, the system structure diagram is shown as follows:

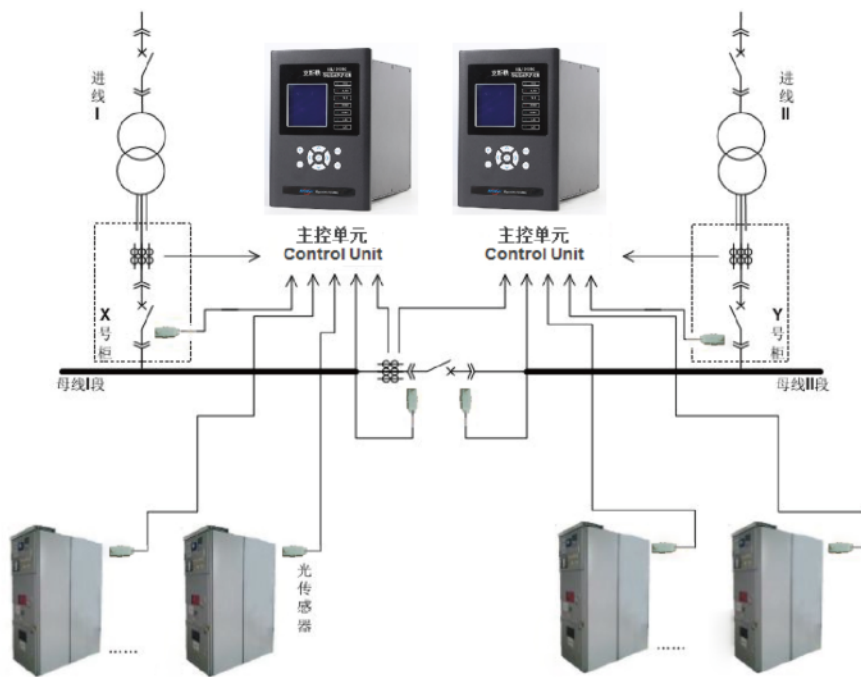

由于配置模块化，系统适合于各种不同场合的电弧光保护应用，可组成从只有一个主控单元的简单系统，到包含多个单元能用于选择性电弧光保护的复杂系统。

系统采用星型连接方式，主控单元和弧光传感器通过线缆连接，若大于16路，可选配弧光扩展单元。

本系统通过主控单元和站内监控系统通信，主控单元可选配2路以太网或RS485、Modbus规约，通过规约支持部颁IEC60870-5-103标准，可方便地介入站内综自系统。

Due to the modular configuration, the system is suitable for a wide variety of arc protection applications, from simple systems with only one main control unit to complex systems with multiple units for selective arc protection.

The system is connected in star mode. The main control unit and arc sensor are connected through cables. If there are more than 16 cables, an arc expansion unit can be selected.

The system communicates with the station monitoring system through the main control unit. The main control unit can be equipped with two Ethernet or RS485 and Modbus protocols. The protocols support the IEC60870-5-103 standard by the Ministry, and can easily intervene in the station integrated automatic system.

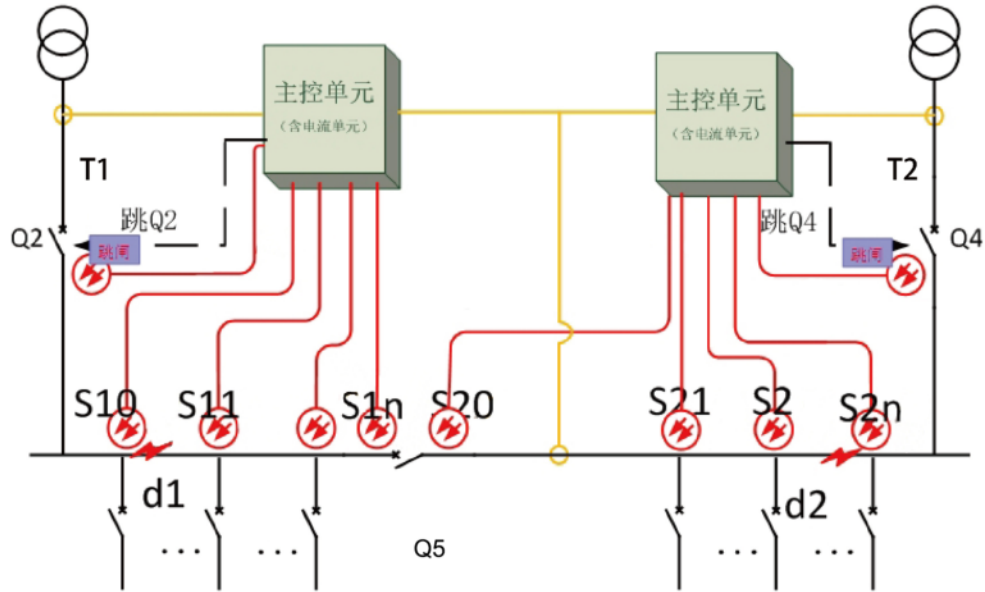

图二 典型配置图

系统分列运行时:

图二 若d1位置发生故障，I母关联弧光传感器(S10…S1n)监测到弧光动作，且T1变低压侧电流判据满足，则I母线区域弧光保护动作，跳1#变压器低压侧开关(Q2)，切除I母故障。

若d2位置发生故障，II母关联弧光传感器(S20…S2n)监测到弧光动作，且T2变低压侧电流判据满足，则II母区域弧光保护动作，跳T2变低压侧开关(Q4)，切除II母故障。

系统并列运行时:

Q4断开，变压器T2退出运行，母联Q5合上，此时系统转入并列运行，由变压器T1带两段母线运行。

若d1位置发生故障，I母关联传感器(S10…S1n)监测到弧光信号，并且T1变低压侧电流增量满足判据，则I母区域弧光保护动作跳T1低压侧开关Q2；

若d2位置发生故障，II母关联传感器(S20…S2n)监测到弧光信号，并且母联电流增量满足判据，则II母区域弧光保护动作跳母联开关Q5。

■ 弧光保护动作时限

Arc protection action time limit

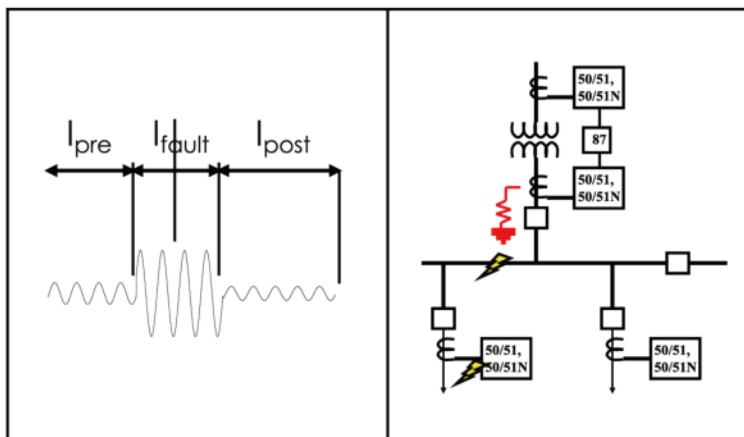

- 弧光采样: 1ms
Arc sampling: 1ms
- 电流采样: 1ms
Current sampling: 1ms
- 节点闭合: 20ms
Contact closed for: 20ms
- 断路器分闸: 30-80ms
Circuit breaker sub-gate: 30-80ms
- 故障切除时间: 1ms+1ms+20ms+40ms=62ms
Failure removal time: 1ms+1ms+20ms+40ms=62ms

系统构成 System composition



母线弧光保护装置
KSL101ARC (H型)



弧光传感器
KSL127ARC

■ 母线弧光保护装置

Medium and high voltage busbar arc protection device

环境条件 Environmental conditions

- ◎ 大气压力: 86kPa~106kPa
Atmospheric pressure: 86kPa ~ 106kPa
- ◎ 环境温度: -10℃~+55℃
Ambient temperature: -10℃ ~ +55℃
- ◎ 相对湿度: 45%~75%
Relative humidity: 45% ~ 75%

额定参数 Rated parameters

- ◎ 工作电源: 110V、220V AC、DC通用
Working power: 110V, 220V AC, DC general
- ◎ 激励量: 交流电流额定值 :1A; 5A
Excitation: AC current rating I_n : 1A; 5A

额定频率 f_n : 50Hz Rated frequency f_n : 50Hz

- ◎ 过载能力: 交流电流回路: 2倍额定电流, 长期连续工作; 40倍额定电流, 允许1S。
Overload capacity: AC current loop: 2 times the rated current, long-term continuous work; 40 times the rated current, allowing 1S.

- 功率消耗：静态功耗：不大于15W（备1个监视点弧光保护功能的最小系统）
Power consumption: Static power consumption: not more than 15W (with a monitoring point of the minimum arc protection system)
- 动作时功耗：不大于15W（备1个监视点弧光保护功能的最小系统）
Action power consumption: not more than 15W
(prepare 1 monitoring point of the minimum arc protection system)

装置技术参数 Device technical parameters

- 电流参数：接口数量：4组电流输入接口；12路电流
Current parameters: Number of interfaces: 4 sets of current input interface; 12 current
精度：0.01A
Accuracy: 0.01A
- 弧光参数：接口数量：16个传感器（可扩展）
arc parameters: Number of interfaces: 16 sensors (expandable)
精度：误差不超过20%
Accuracy: the error does not exceed 20%
- 跳闸出口：12个
Trip Outlet: 12
- 动作时间：< 20ms
Action time: < 20ms
- 通讯接口：2路RS485接口，103规约、Modbus规约
Communication interface: 2-way Ethernet or 2-way RS485, 103 protocol, Modbus protocol



■ KSL101ARC (H型) 的二次原理图 Secondary principle diagram of KSL101ARC (H)

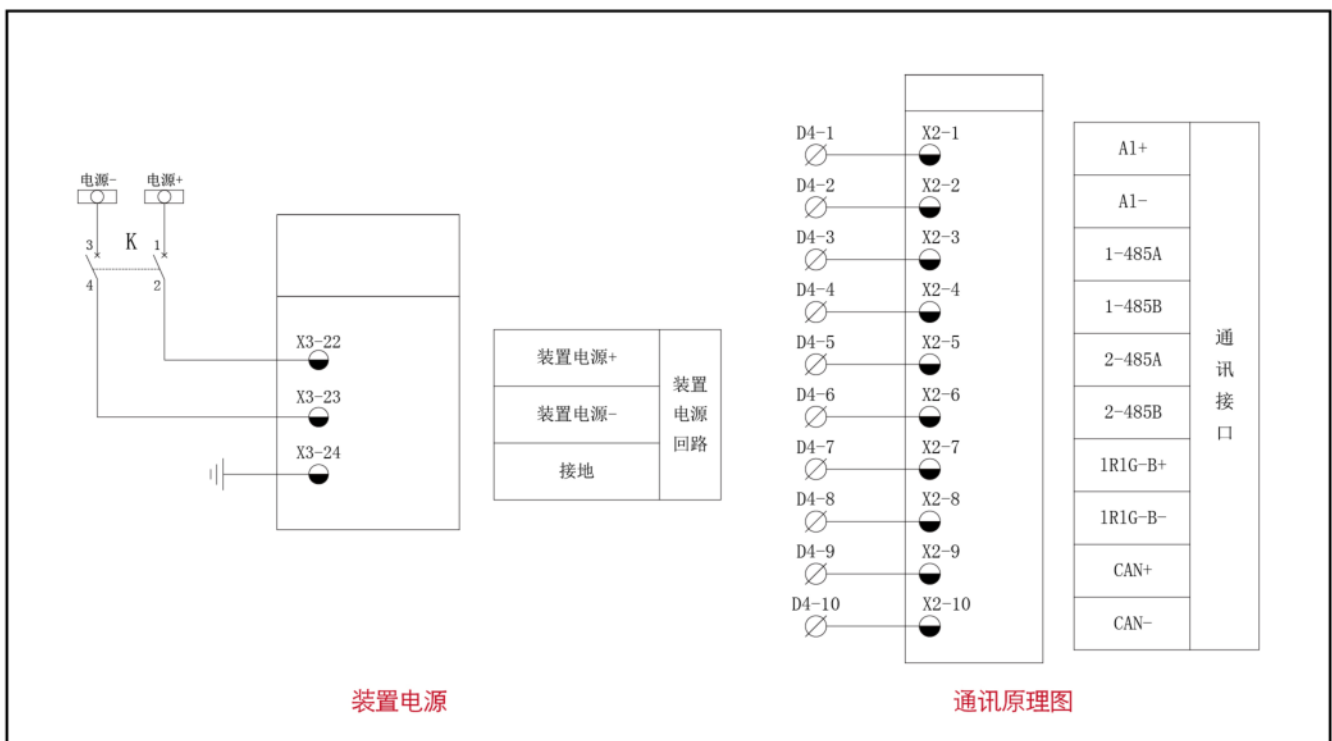
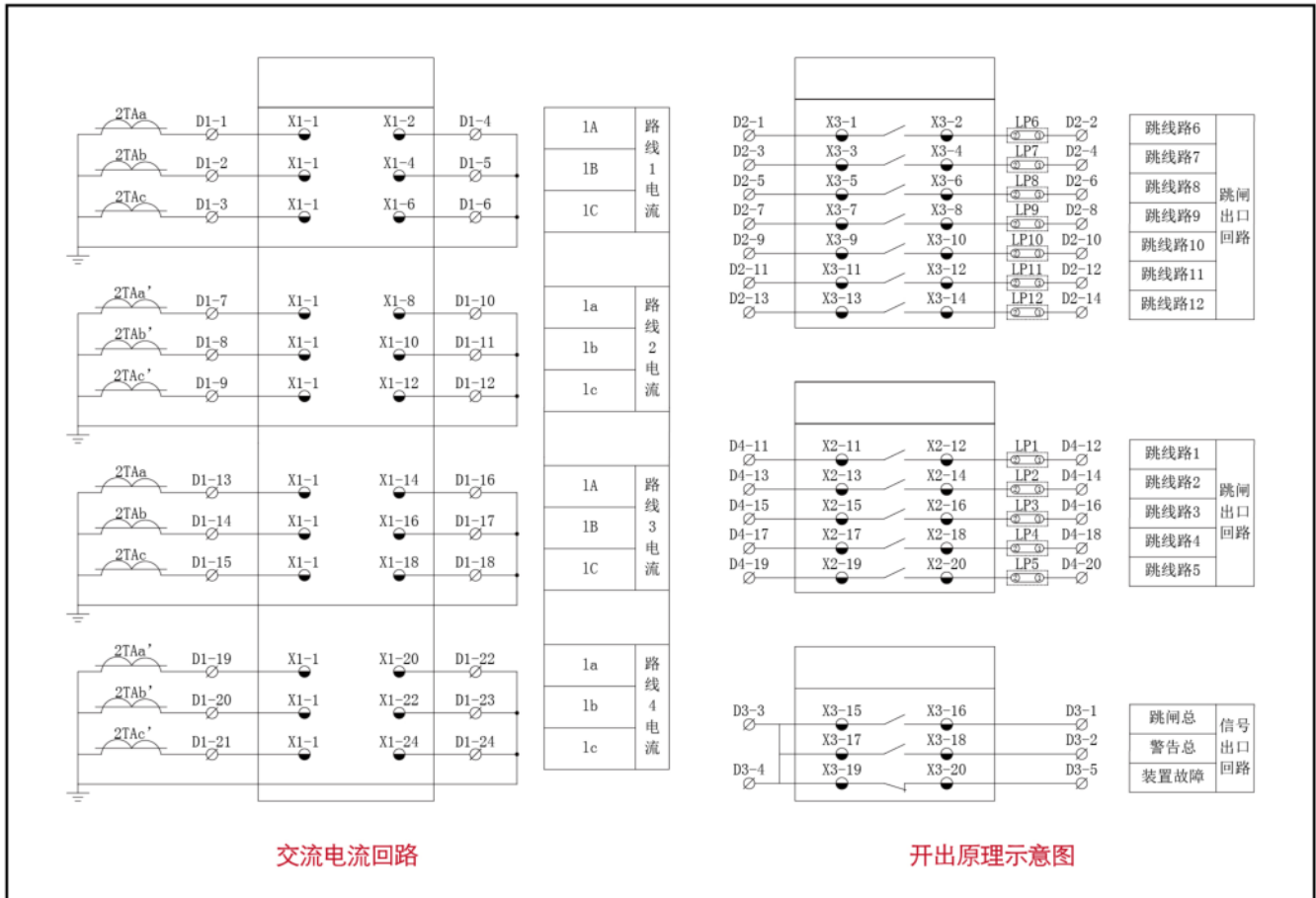

弧光扩展单元 Arc Expansion Unit

1. 扩展单元包含16路弧光接口（X2和X3），1个12位端子（X1），两个拨码开关（SW1-SW2），两个RJ45(未用)。

1.The expansion unit includes 16-channel arc light interfaces (X2 and X3), 1 12-pin terminal (X1), two DIP switches (SW1-SW2), and two unused RJ45 ports.

2、扩展单元与主控采用CAN总线通讯，扩展单元12位端子的1脚为CANH，接主控单元插件10位端子9脚，扩展单元12位端子的2脚为CANL，接主控单元插件10位端子10脚。即扩展单元X1模块1、2号端子接入母线主机的X2模块9、10号端子。带多个扩展单元，就把多个扩展单元并接到母线主机的X2的9和10即可。

2.The expansion unit communicates with the main controller via CAN bus. Pin 1 of the 12-pin terminal (X1) of the expansion unit is CANH, connected to Pin 9 of the 10-pin terminal of the main controller's plug-in module; Pin 2 of X1 is CANL, connected to Pin 10 of the 10-pin terminal of the main controller's plug-in module. That is, Pins 1 and 2 of the expansion unit's X1 module are connected to Pins 9 and 10 of the bus host's X2 module. For multiple expansion units, connect them in parallel to Pins 9 and 10 of the bus host's X2 module.

3、扩展单元X1模块端子的10、11脚为电源接口，12脚为EARTH，10脚为L/+，11脚为N/-，交直流通用220V。

3.Pins 10 and 11 of the expansion unit's X1 module are power interfaces, Pin 12 is EARTH, Pin 10 is L/+, and Pin 11 is N/-, which is universal for AC/DC 220V.

4、拨码开关SW1为本扩展模块的CAN通讯地址，比如bit1单独拨下，地址为1；bit2单独拨下，地址为2；bit1和bit2同时拨下，地址为3。

4.DIP switch SW1 is the CAN communication address of this expansion module. For example, if bit1 is toggled down alone, the address is 1; if bit2 is toggled down alone, the address is 2; if both bit1 and bit2 are toggled down, the address is 3.

5、两台扩展模块地址出厂时，地址设置为1和2。

5.The factory-set addresses of two expansion modules are 1 and 2 respectively.

6、拨码开关SW2为CAN总线终端电阻，比如投入，出厂前都已拨下，投入。如主控带两台以上扩展单元，可依据现场情况，仅在一台扩展单元处投入即可。

6.DIP switch SW2 is the CAN bus terminating resistor (enabled when toggled down). All are toggled down (enabled) before leaving the factory. If the main controller is connected to more than two expansion units, only need to enable it on one expansion unit according to on-site conditions.

7、另一侧的两个RJ45未用，拨码开关SW3需保持在未拨下状态。

7.The two RJ45 ports on the other side are unused, and DIP switch SW3 must be kept in the untoggled state.

8、扩展单元使用时，只需按照第2条接好线，按照第4条设置好地址和终端电阻，主控不许进行其他设置即可使用。在主控液晶显示界面，弧光测值界面，在16路弧光信号后，第17个测值为扩展单元1地址为1的弧光测值（16进制），后面按照地址顺序（2、3、4...）依次为扩展单元2、3、4...上送的弧光测值。

8.When using the expansion unit, simply wire it as specified in Clause 2, set the address and terminating resistor as per Clause 4—no additional settings are required on the main controller. On the LCD display interface of the main controller (arc light measurement interface), after the 16-channel arc light signals, the 17th measurement value is the arc light measurement value (hexadecimal) of the expansion unit with address 1, followed by the arc light measurement values uploaded by expansion units 2, 3, 4... in address order.

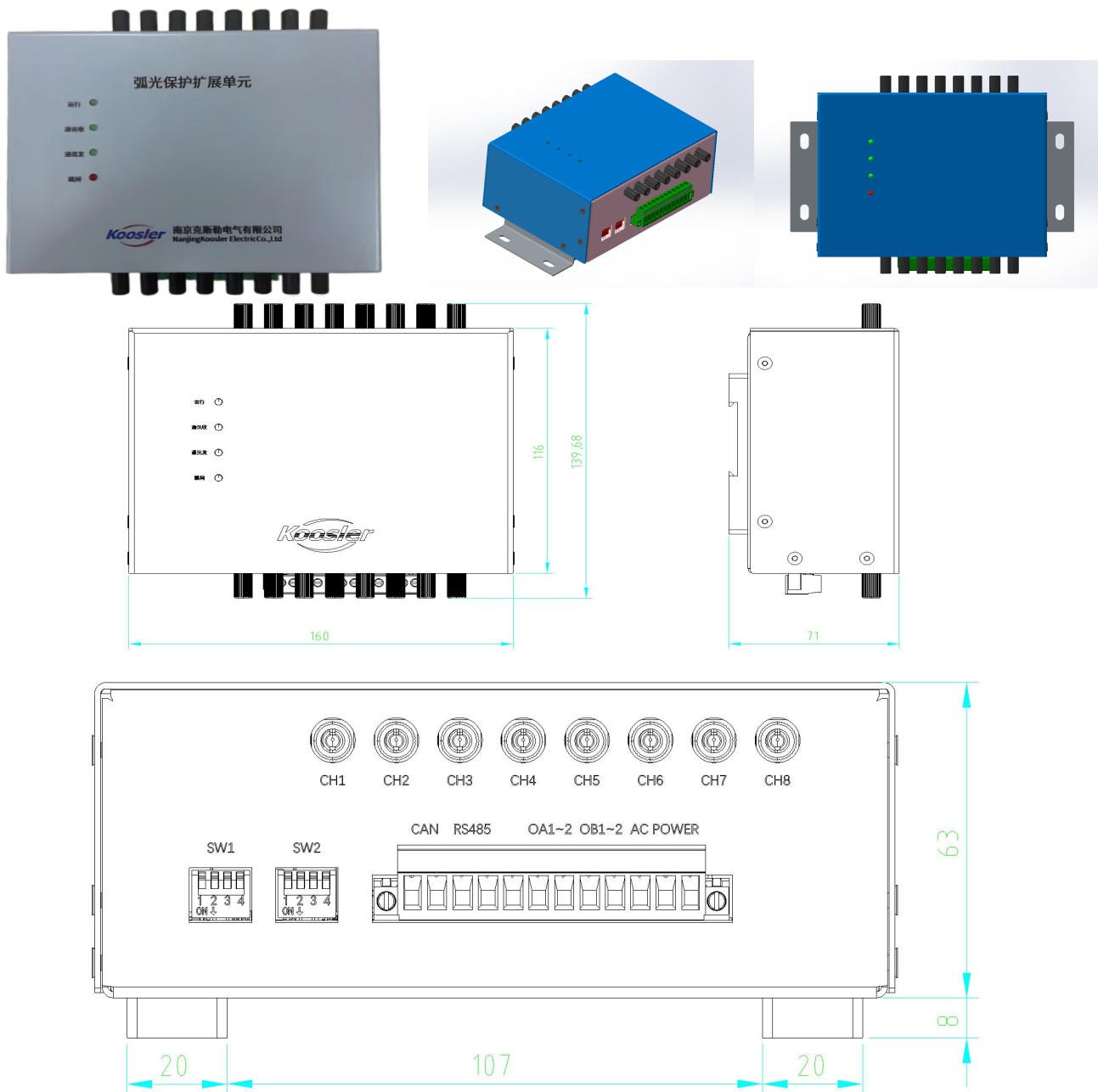

馈线智能弧光保护系统KSL101ARC (F型)

Feeder Intelligent Arc Protection System KSL101ARC (F)

■ 产品简述

Product description

○ 馈线智能弧光保护系统KSL101ARC (F型) 应用于中高压开关柜、电缆分支箱、动力柜、配电箱等。

Feeder intelligent arc protection system KSL101ARC(F) used in medium voltage cabinets, cable branch boxes, power cabinets power distribution box.

■ 系统构成

System composition

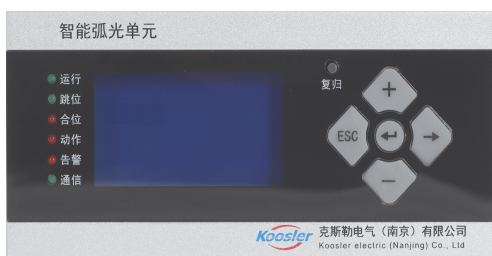

馈线智能弧光保护装置
KSL101ARC(F型)



弧光传感器
KSL127 ARC

■ 馈线智能弧光保护装置

Feeder intelligent arc protection device

装置技术参数 Device technical parameters

○ 工作电源: 110V、220V AC、DC通用

Working power: 110V, 220V AC, DC general

○ 整机功耗: < 15W

Power consumption: <15W

○ 接口: 4个弧光传感器接口

Interface: 4 arc sensor interface

○ 交流输入: 1组3路电流

AC input: 1 groups of 3 currents

○ 跳闸出口: 2个电磁继电器出口

Trip output: two electromagnetic relay exit

◎ 动作时间: < 20ms

Action time: < 20ms

◎ 通讯接口: 1路RS485、Modbus规约

Communication interface: 1 RS485, Modbus protocol

◎ 运行环境: -20℃~ +55℃

Run the ring mirror: -20 °C ~ +55 °Cs

■ KSL101ARC (F型)的二次原理图
Secondary principle diagram of KSL101ARC (F)

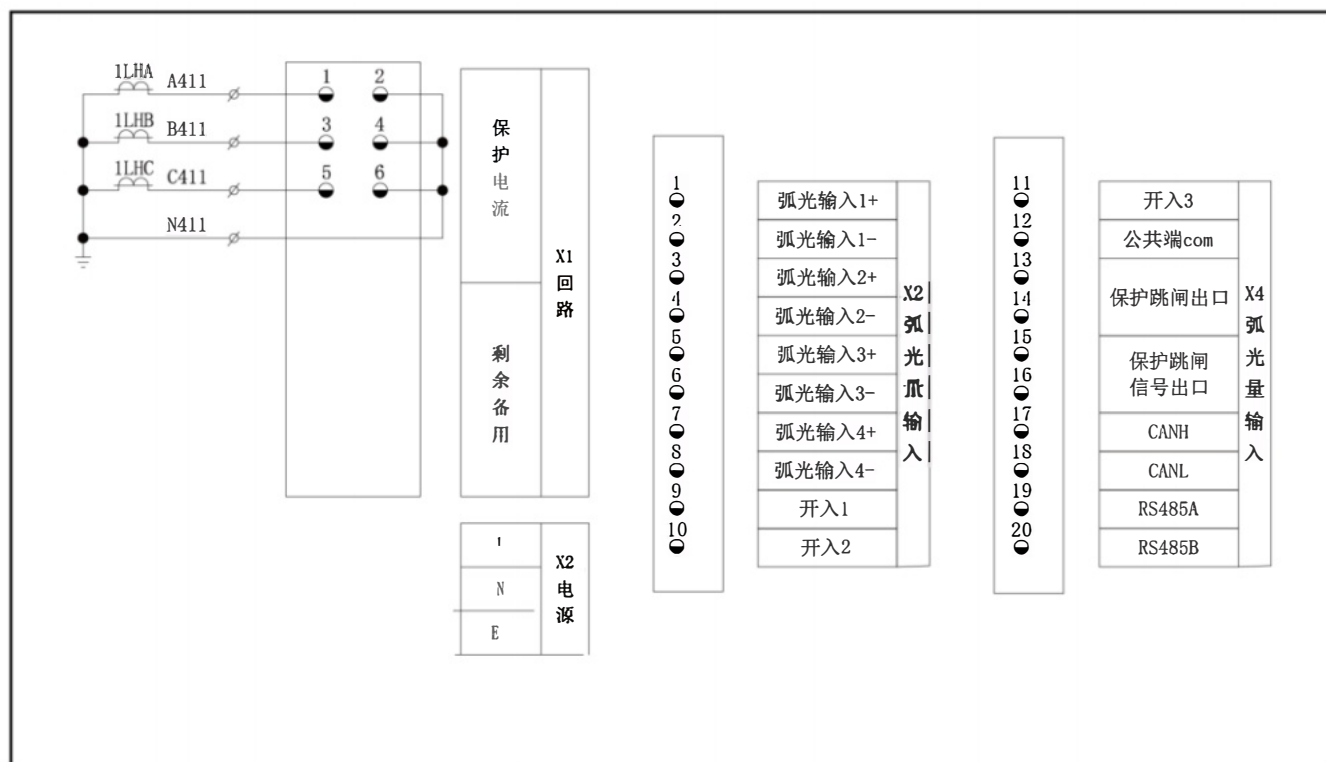

弧光传感器KSL127ARC

Arc sensor KSL 127ARC

■ 电弧光的发生过程

The process of arc light

开关柜发生弧光故障时，开关柜内气体经过压缩、发展、发热、最后爆炸，整个过程仅需500ms，在发展过程中，柜内母排绝缘，柜体均燃烧汽化。

Switchgear arc fault occurs, the switch cabinet gas compression, development, fever, the final explosion, the whole process only 500ms, in the development process, the cabinet bus insulation, the cabinet are burning vaporization.

■ 弧光的光学特点

The Optical Characteristics of Arc

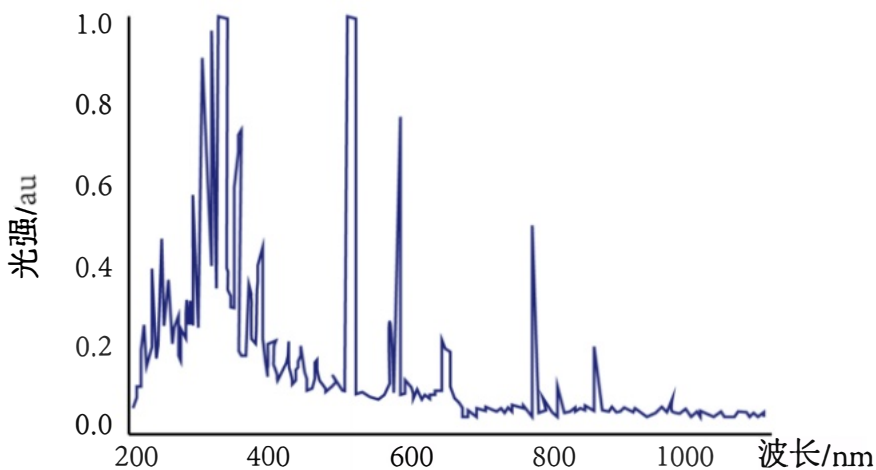

图三 铜电极电弧光光谱图

◎电弧光的能量主要集中在230–380nm的紫外区、380–400nm的紫光和500–550nm的可见光区范围；
The energy of the arc light mainly concentrated in the ultraviolet region of 230–380nm, the violet light of 380–400nm and the visible light region of 500–550nm;

◎电弧光中500–550nm的可见光可导致运行维护人员短暂性失明；
500–550nm in the arc light visible light can cause the operation and maintenance personnel transient blindness;

弧光传感器要屏蔽各种普通可见光和红外区。
The arc sensor should shield all kinds of ordinary visible and infrared areas.

波长区域 (单位: nm)	区域名称
1–200	真空紫外区
200–300	远紫外区
300–380	近紫外区
380–420	紫光
420–450	蓝光
450–490	青光
490–560	绿光
560–590	黄光
590–620	橙光
620–780	红光
780–1500	近红外区
1500–10000	中红外区
1000–1000000	远红外区

■ 弧光传感器KSL127ARC的特点

Characteristics of the arc sensor KSL127ARC

- 能够有效滤掉各种普通可见光和100%屏蔽红外区；能够有效辨别200nm-400nm（紫外区、近紫外区、部分紫光）的电弧光，有别于一些制造商研发的单一型紫外光传感器。

Can effectively filter out a variety of ordinary visible light and 100% shielded infrared area; can effectively identify 200nm-400nm (UV, near ultraviolet, part of the purple) arc light, different from some manufacturers developed a single type of UV light sensor.

- 探测灵敏度（200nm-400nm）：0.01mW/cm²
Detection sensitivity (200nm-400nm):0.01mW/cm²

- 平均无故障时间MTBF：100000小时；
Mean time between failures MTBF: 100,000 hours;

- 测量角度：0° ~210° 的测量角度，相较于其他最大测量角度只有120° 的弧光传感器，真正做到无死角测量；
Measuring angle:0° ~ 210° measurement angle, compared to other maximum measurement angle of only 120° arc sensor, really do not have dead angle measurement;

- 是国际国内为数不多具有独立知识产权的弧光传感器制造商。
Is one of the few domestic and international intellectual property rights of the arc sensor manufacturers.



弧光传感器
KSL127ARC

尺寸：高度35.8mm，最大直径16mm（不包含外部固定螺母）
（弧光传感器外径直径16mm，配套固定支架开孔需 > = 16.5mm）
Dimensions: Height 35.8mm, maximum diameter 16mm (excluding external fixing nuts)(The outer diameter of the arc light sensor is 16mm, and the mounting hole of the matching fixing bracket should be 16.5mm)

■ 弧光传感器的应用场合

Application of arc sensor

- 适用于中低压开关柜、低压配电控制箱、箱式变电站等设备的弧光监测；
Suitable for low-voltage switchgear, low-voltage distribution control box, box-type substation equipment such as arc monitoring;
- 适用于管道走廊中对电缆接头、电缆分支箱、电缆弯曲等位置的弧光检测；
It is suitable for arc detection of cable joints, cable branch boxes, cable bending and so on in pipeline corridor;
- 适用于发电机转子部分空间内的弧光检测；
Applicable to arc detection within the generator rotor space;
- 适用于绝缘子在污秽、覆冰等恶劣环境下发生闪络时的弧光检测。
Applicable to the insulator in the filthy, ice and other harsh environments flash occurs when the arc detection.



安装示意图及尺寸图

Installation diagram and Dimensional drawing

■ 安装示意图

Installation diagram

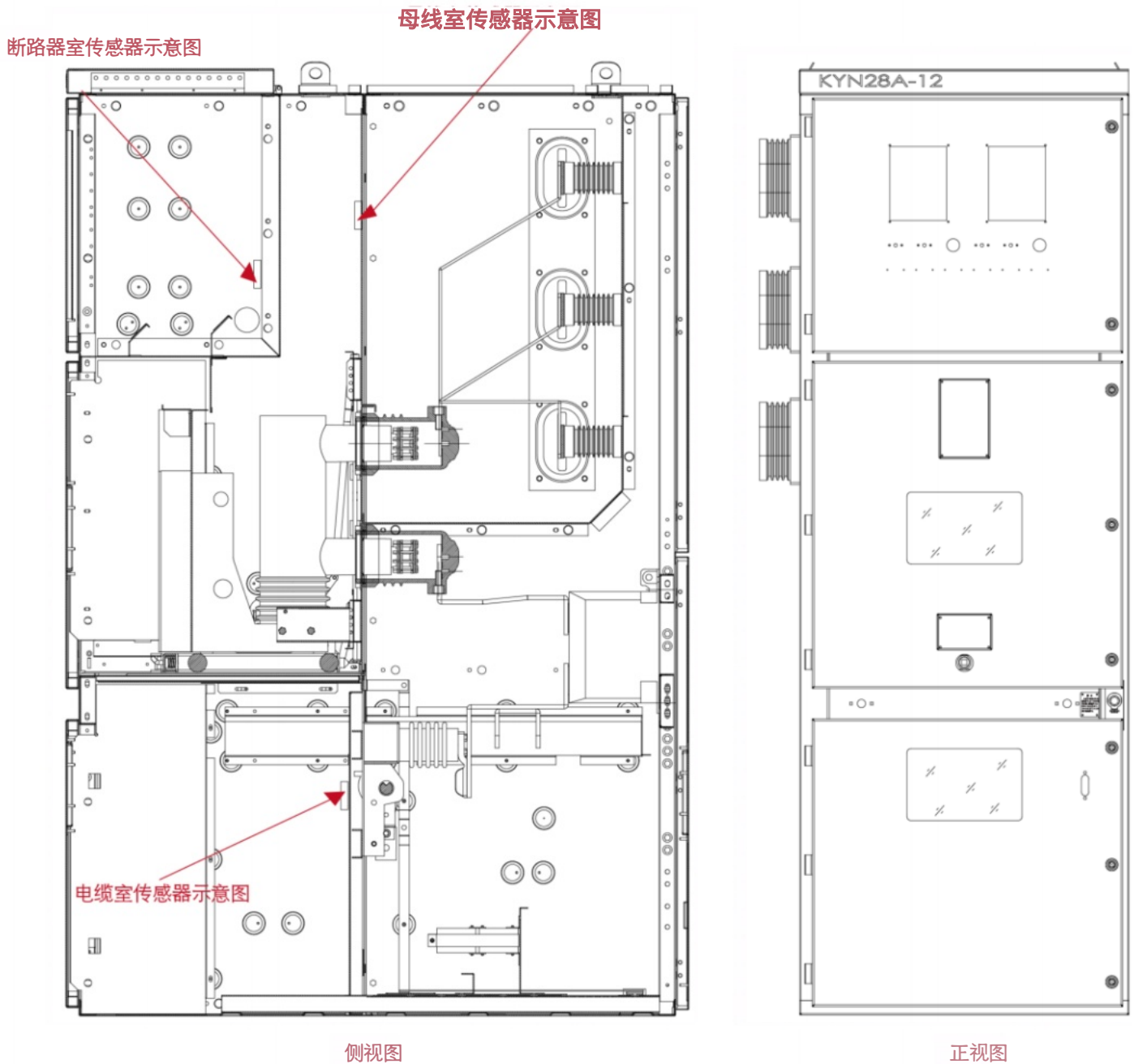

尺寸图 Dimensional drawing

注：下图中尺寸单位均为mm。

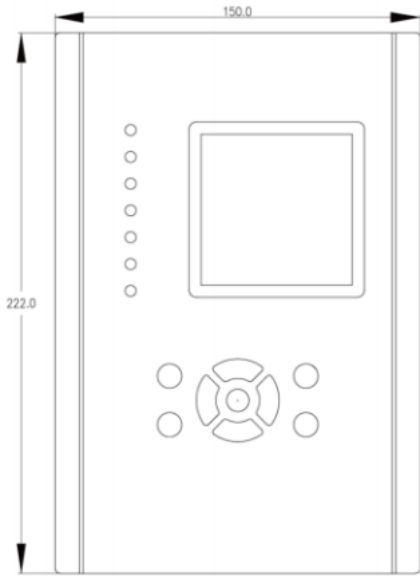

外形尺寸图

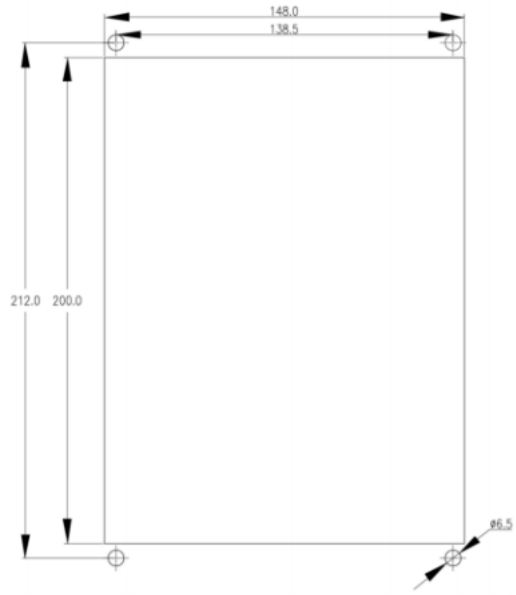

开孔尺寸图

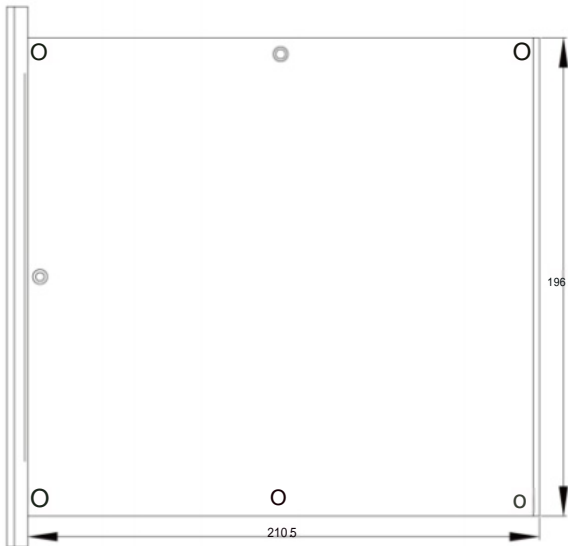

端子示意图

TX	ZX	3X	4X																																																																																																																																																																																																																																																																																																																																																																																																																																																																																																																																																																																																																					
<table border="1"> <tr><td>1</td><td>1A</td><td>1B</td><td>1C</td><td>1D</td><td>1E</td></tr> <tr><td>2</td><td>2A</td><td>2B</td><td>2C</td><td>2D</td><td>2E</td></tr> <tr><td>3</td><td>3A</td><td>3B</td><td>3C</td><td>3D</td><td>3E</td></tr> <tr><td>4</td><td>4A</td><td>4B</td><td>4C</td><td>4D</td><td>4E</td></tr> <tr><td>5</td><td>5A</td><td>5B</td><td>5C</td><td>5D</td><td>5E</td></tr> <tr><td>6</td><td>6A</td><td>6B</td><td>6C</td><td>6D</td><td>6E</td></tr> <tr><td>7</td><td>7A</td><td>7B</td><td>7C</td><td>7D</td><td>7E</td></tr> <tr><td>8</td><td>8A</td><td>8B</td><td>8C</td><td>8D</td><td>8E</td></tr> <tr><td>9</td><td>9A</td><td>9B</td><td>9C</td><td>9D</td><td>9E</td></tr> <tr><td>10</td><td>10A</td><td>10B</td><td>10C</td><td>10D</td><td>10E</td></tr> <tr><td>11</td><td>11A</td><td>11B</td><td>11C</td><td>11D</td><td>11E</td></tr> <tr><td>12</td><td>12A</td><td>12B</td><td>12C</td><td>12D</td><td>12E</td></tr> <tr><td>13</td><td>13A</td><td>13B</td><td>13C</td><td>13D</td><td>13E</td></tr> <tr><td>14</td><td>14A</td><td>14B</td><td>14C</td><td>14D</td><td>14E</td></tr> <tr><td>15</td><td>15A</td><td>15B</td><td>15C</td><td>15D</td><td>15E</td></tr> <tr><td>16</td><td>16A</td><td>16B</td><td>16C</td><td>16D</td><td>16E</td></tr> <tr><td>17</td><td>17A</td><td>17B</td><td>17C</td><td>17D</td><td>17E</td></tr> <tr><td>18</td><td>18A</td><td>18B</td><td>18C</td><td>18D</td><td>18E</td></tr> <tr><td>19</td><td>19A</td><td>19B</td><td>19C</td><td>19D</td><td>19E</td></tr> <tr><td>20</td><td>20A</td><td>20B</td><td>20C</td><td>20D</td><td>20E</td></tr> <tr><td>21</td><td>21A</td><td>21B</td><td>21C</td><td>21D</td><td>21E</td></tr> <tr><td>22</td><td>22A</td><td>22B</td><td>22C</td><td>22D</td><td>22E</td></tr> <tr><td>23</td><td>23A</td><td>23B</td><td>23C</td><td>23D</td><td>23E</td></tr> <tr><td>24</td><td>24A</td><td>24B</td><td>24C</td><td>24D</td><td>24E</td></tr> <tr><td>25</td><td>25A</td><td>25B</td><td>25C</td><td>25D</td><td>25E</td></tr> <tr><td>26</td><td>26A</td><td>26B</td><td>26C</td><td>26D</td><td>26E</td></tr> <tr><td>27</td><td>27A</td><td>27B</td><td>27C</td><td>27D</td><td>27E</td></tr> <tr><td>28</td><td>28A</td><td>28B</td><td>28C</td><td>28D</td><td>28E</td></tr> <tr><td>29</td><td>29A</td><td>29B</td><td>29C</td><td>29D</td><td>29E</td></tr> <tr><td>30</td><td>30A</td><td>30B</td><td>30C</td><td>30D</td><td>30E</td></tr> <tr><td>31</td><td>31A</td><td>31B</td><td>31C</td><td>31D</td><td>31E</td></tr> <tr><td>32</td><td>32A</td><td>32B</td><td>32C</td><td>32D</td><td>32E</td></tr> <tr><td>33</td><td>33A</td><td>33B</td><td>33C</td><td>33D</td><td>33E</td></tr> <tr><td>34</td><td>34A</td><td>34B</td><td>34C</td><td>34D</td><td>34E</td></tr> <tr><td>35</td><td>35A</td><td>35B</td><td>35C</td><td>35D</td><td>35E</td></tr> <tr><td>36</td><td>36A</td><td>36B</td><td>36C</td><td>36D</td><td>36E</td></tr> <tr><td>37</td><td>37A</td><td>37B</td><td>37C</td><td>37D</td><td>37E</td></tr> <tr><td>38</td><td>38A</td><td>38B</td><td>38C</td><td>38D</td><td>38E</td></tr> <tr><td>39</td><td>39A</td><td>39B</td><td>39C</td><td>39D</td><td>39E</td></tr> <tr><td>40</td><td>40A</td><td>40B</td><td>40C</td><td>40D</td><td>40E</td></tr> <tr><td>41</td><td>41A</td><td>41B</td><td>41C</td><td>41D</td><td>41E</td></tr> <tr><td>42</td><td>42A</td><td>42B</td><td>42C</td><td>42D</td><td>42E</td></tr> <tr><td>43</td><td>43A</td><td>43B</td><td>43C</td><td>43D</td><td>43E</td></tr> <tr><td>44</td><td>44A</td><td>44B</td><td>44C</td><td>44D</td><td>44E</td></tr> <tr><td>45</td><td>45A</td><td>45B</td><td>45C</td><td>45D</td><td>45E</td></tr> <tr><td>46</td><td>46A</td><td>46B</td><td>46C</td><td>46D</td><td>46E</td></tr> <tr><td>47</td><td>47A</td><td>47B</td><td>47C</td><td>47D</td><td>47E</td></tr> <tr><td>48</td><td>48A</td><td>48B</td><td>48C</td><td>48D</td><td>48E</td></tr> <tr><td>49</td><td>49A</td><td>49B</td><td>49C</td><td>49D</td><td>49E</td></tr> <tr><td>50</td><td>50A</td><td>50B</td><td>50C</td><td>50D</td><td>50E</td></tr> <tr><td>51</td><td>51A</td><td>51B</td><td>51C</td><td>51D</td><td>51E</td></tr> <tr><td>52</td><td>52A</td><td>52B</td><td>52C</td><td>52D</td><td>52E</td></tr> <tr><td>53</td><td>53A</td><td>53B</td><td>53C</td><td>53D</td><td>53E</td></tr> <tr><td>54</td><td>54A</td><td>54B</td><td>54C</td><td>54D</td><td>54E</td></tr> <tr><td>55</td><td>55A</td><td>55B</td><td>55C</td><td>55D</td><td>55E</td></tr> <tr><td>56</td><td>56A</td><td>56B</td><td>56C</td><td>56D</td><td>56E</td></tr> <tr><td>57</td><td>57A</td><td>57B</td><td>57C</td><td>57D</td><td>57E</td></tr> <tr><td>58</td><td>58A</td><td>58B</td><td>58C</td><td>58D</td><td>58E</td></tr> <tr><td>59</td><td>59A</td><td>59B</td><td>59C</td><td>59D</td><td>59E</td></tr> <tr><td>60</td><td>60A</td><td>60B</td><td>60C</td><td>60D</td><td>60E</td></tr> <tr><td>61</td><td>61A</td><td>61B</td><td>61C</td><td>61D</td><td>61E</td></tr> <tr><td>62</td><td>62A</td><td>62B</td><td>62C</td><td>62D</td><td>62E</td></tr> <tr><td>63</td><td>63A</td><td>63B</td><td>63C</td><td>63D</td><td>63E</td></tr> <tr><td>64</td><td>64A</td><td>64B</td><td>64C</td><td>64D</td><td>64E</td></tr> <tr><td>65</td><td>65A</td><td>65B</td><td>65C</td><td>65D</td><td>65E</td></tr> <tr><td>66</td><td>66A</td><td>66B</td><td>66C</td><td>66D</td><td>66E</td></tr> <tr><td>67</td><td>67A</td><td>67B</td><td>67C</td><td>67D</td><td>67E</td></tr> <tr><td>68</td><td>68A</td><td>68B</td><td>68C</td><td>68D</td><td>68E</td></tr> <tr><td>69</td><td>69A</td><td>69B</td><td>69C</td><td>69D</td><td>69E</td></tr> <tr><td>70</td><td>70A</td><td>70B</td><td>70C</td><td>70D</td><td>70E</td></tr> <tr><td>71</td><td>71A</td><td>71B</td><td>71C</td><td>71D</td><td>71E</td></tr> <tr><td>72</td><td>72A</td><td>72B</td><td>72C</td><td>72D</td><td>72E</td></tr> <tr><td>73</td><td>73A</td><td>73B</td><td>73C</td><td>73D</td><td>73E</td></tr> <tr><td>74</td><td>74A</td><td>74B</td><td>74C</td><td>74D</td><td>74E</td></tr> <tr><td>75</td><td>75A</td><td>75B</td><td>75C</td><td>75D</td><td>75E</td></tr> <tr><td>76</td><td>76A</td><td>76B</td><td>76C</td><td>76D</td><td>76E</td></tr> <tr><td>77</td><td>77A</td><td>77B</td><td>77C</td><td>77D</td><td>77E</td></tr> <tr><td>78</td><td>78A</td><td>78B</td><td>78C</td><td>78D</td><td>78E</td></tr> <tr><td>79</td><td>79A</td><td>79B</td><td>79C</td><td>79D</td><td>79E</td></tr> <tr><td>80</td><td>80A</td><td>80B</td><td>80C</td><td>80D</td><td>80E</td></tr> <tr><td>81</td><td>81A</td><td>81B</td><td>81C</td><td>81D</td><td>81E</td></tr> <tr><td>82</td><td>82A</td><td>82B</td><td>82C</td><td>82D</td><td>82E</td></tr> <tr><td>83</td><td>83A</td><td>83B</td><td>83C</td><td>83D</td><td>83E</td></tr> <tr><td>84</td><td>84A</td><td>84B</td><td>84C</td><td>84D</td><td>84E</td></tr> <tr><td>85</td><td>85A</td><td>85B</td><td>85C</td><td>85D</td><td>85E</td></tr> <tr><td>86</td><td>86A</td><td>86B</td><td>86C</td><td>86D</td><td>86E</td></tr> <tr><td>87</td><td>87A</td><td>87B</td><td>87C</td><td>87D</td><td>87E</td></tr> <tr><td>88</td><td>88A</td><td>88B</td><td>88C</td><td>88D</td><td>88E</td></tr> <tr><td>89</td><td>89A</td><td>89B</td><td>89C</td><td>89D</td><td>89E</td></tr> <tr><td>90</td><td>90A</td><td>90B</td><td>90C</td><td>90D</td><td>90E</td></tr> <tr><td>91</td><td>91A</td><td>91B</td><td>91C</td><td>91D</td><td>91E</td></tr> <tr><td>92</td><td>92A</td><td>92B</td><td>92C</td><td>92D</td><td>92E</td></tr> <tr><td>93</td><td>93A</td><td>93B</td><td>93C</td><td>93D</td><td>93E</td></tr> <tr><td>94</td><td>94A</td><td>94B</td><td>94C</td><td>94D</td><td>94E</td></tr> <tr><td>95</td><td>95A</td><td>95B</td><td>95C</td><td>95D</td><td>95E</td></tr> <tr><td>96</td><td>96A</td><td>96B</td><td>96C</td><td>96D</td><td>96E</td></tr> <tr><td>97</td><td>97A</td><td>97B</td><td>97C</td><td>97D</td><td>97E</td></tr> <tr><td>98</td><td>98A</td><td>98B</td><td>98C</td><td>98D</td><td>98E</td></tr> <tr><td>99</td><td>99A</td><td>99B</td><td>99C</td><td>99D</td><td>99E</td></tr> <tr><td>100</td><td>100A</td><td>100B</td><td>100C</td><td>100D</td><td>100E</td></tr> </table>	1	1A	1B	1C	1D	1E	2	2A	2B	2C	2D	2E	3	3A	3B	3C	3D	3E	4	4A	4B	4C	4D	4E	5	5A	5B	5C	5D	5E	6	6A	6B	6C	6D	6E	7	7A	7B	7C	7D	7E	8	8A	8B	8C	8D	8E	9	9A	9B	9C	9D	9E	10	10A	10B	10C	10D	10E	11	11A	11B	11C	11D	11E	12	12A	12B	12C	12D	12E	13	13A	13B	13C	13D	13E	14	14A	14B	14C	14D	14E	15	15A	15B	15C	15D	15E	16	16A	16B	16C	16D	16E	17	17A	17B	17C	17D	17E	18	18A	18B	18C	18D	18E	19	19A	19B	19C	19D	19E	20	20A	20B	20C	20D	20E	21	21A	21B	21C	21D	21E	22	22A	22B	22C	22D	22E	23	23A	23B	23C	23D	23E	24	24A	24B	24C	24D	24E	25	25A	25B	25C	25D	25E	26	26A	26B	26C	26D	26E	27	27A	27B	27C	27D	27E	28	28A	28B	28C	28D	28E	29	29A	29B	29C	29D	29E	30	30A	30B	30C	30D	30E	31	31A	31B	31C	31D	31E	32	32A	32B	32C	32D	32E	33	33A	33B	33C	33D	33E	34	34A	34B	34C	34D	34E	35	35A	35B	35C	35D	35E	36	36A	36B	36C	36D	36E	37	37A	37B	37C	37D	37E	38	38A	38B	38C	38D	38E	39	39A	39B	39C	39D	39E	40	40A	40B	40C	40D	40E	41	41A	41B	41C	41D	41E	42	42A	42B	42C	42D	42E	43	43A	43B	43C	43D	43E	44	44A	44B	44C	44D	44E	45	45A	45B	45C	45D	45E	46	46A	46B	46C	46D	46E	47	47A	47B	47C	47D	47E	48	48A	48B	48C	48D	48E	49	49A	49B	49C	49D	49E	50	50A	50B	50C	50D	50E	51	51A	51B	51C	51D	51E	52	52A	52B	52C	52D	52E	53	53A	53B	53C	53D	53E	54	54A	54B	54C	54D	54E	55	55A	55B	55C	55D	55E	56	56A	56B	56C	56D	56E	57	57A	57B	57C	57D	57E	58	58A	58B	58C	58D	58E	59	59A	59B	59C	59D	59E	60	60A	60B	60C	60D	60E	61	61A	61B	61C	61D	61E	62	62A	62B	62C	62D	62E	63	63A	63B	63C	63D	63E	64	64A	64B	64C	64D	64E	65	65A	65B	65C	65D	65E	66	66A	66B	66C	66D	66E	67	67A	67B	67C	67D	67E	68	68A	68B	68C	68D	68E	69	69A	69B	69C	69D	69E	70	70A	70B	70C	70D	70E	71	71A	71B	71C	71D	71E	72	72A	72B	72C	72D	72E	73	73A	73B	73C	73D	73E	74	74A	74B	74C	74D	74E	75	75A	75B	75C	75D	75E	76	76A	76B	76C	76D	76E	77	77A	77B	77C	77D	77E	78	78A	78B	78C	78D	78E	79	79A	79B	79C	79D	79E	80	80A	80B	80C	80D	80E	81	81A	81B	81C	81D	81E	82	82A	82B	82C	82D	82E	83	83A	83B	83C	83D	83E	84	84A	84B	84C	84D	84E	85	85A	85B	85C	85D	85E	86	86A	86B	86C	86D	86E	87	87A	87B	87C	87D	87E	88	88A	88B	88C	88D	88E	89	89A	89B	89C	89D	89E	90	90A	90B	90C	90D	90E	91	91A	91B	91C	91D	91E	92	92A	92B	92C	92D	92E	93	93A	93B	93C	93D	93E	94	94A	94B	94C	94D	94E	95	95A	95B	95C	95D	95E	96	96A	96B	96C	96D	96E	97	97A	97B	97C	97D	97E	98	98A	98B	98C	98D	98E	99	99A	99B	99C	99D	99E	100	100A	100B	100C	100D	100E
1	1A	1B	1C	1D	1E																																																																																																																																																																																																																																																																																																																																																																																																																																																																																																																																																																																																																			
2	2A	2B	2C	2D	2E																																																																																																																																																																																																																																																																																																																																																																																																																																																																																																																																																																																																																			
3	3A	3B	3C	3D	3E																																																																																																																																																																																																																																																																																																																																																																																																																																																																																																																																																																																																																			
4	4A	4B	4C	4D	4E																																																																																																																																																																																																																																																																																																																																																																																																																																																																																																																																																																																																																			
5	5A	5B	5C	5D	5E																																																																																																																																																																																																																																																																																																																																																																																																																																																																																																																																																																																																																			
6	6A	6B	6C	6D	6E																																																																																																																																																																																																																																																																																																																																																																																																																																																																																																																																																																																																																			
7	7A	7B	7C	7D	7E																																																																																																																																																																																																																																																																																																																																																																																																																																																																																																																																																																																																																			
8	8A	8B	8C	8D	8E																																																																																																																																																																																																																																																																																																																																																																																																																																																																																																																																																																																																																			
9	9A	9B	9C	9D	9E																																																																																																																																																																																																																																																																																																																																																																																																																																																																																																																																																																																																																			
10	10A	10B	10C	10D	10E																																																																																																																																																																																																																																																																																																																																																																																																																																																																																																																																																																																																																			
11	11A	11B	11C	11D	11E																																																																																																																																																																																																																																																																																																																																																																																																																																																																																																																																																																																																																			
12	12A	12B	12C	12D	12E																																																																																																																																																																																																																																																																																																																																																																																																																																																																																																																																																																																																																			
13	13A	13B	13C	13D	13E																																																																																																																																																																																																																																																																																																																																																																																																																																																																																																																																																																																																																			
14	14A	14B	14C	14D	14E																																																																																																																																																																																																																																																																																																																																																																																																																																																																																																																																																																																																																			
15	15A	15B	15C	15D	15E																																																																																																																																																																																																																																																																																																																																																																																																																																																																																																																																																																																																																			
16	16A	16B	16C	16D	16E																																																																																																																																																																																																																																																																																																																																																																																																																																																																																																																																																																																																																			
17	17A	17B	17C	17D	17E																																																																																																																																																																																																																																																																																																																																																																																																																																																																																																																																																																																																																			
18	18A	18B	18C	18D	18E																																																																																																																																																																																																																																																																																																																																																																																																																																																																																																																																																																																																																			
19	19A	19B	19C	19D	19E																																																																																																																																																																																																																																																																																																																																																																																																																																																																																																																																																																																																																			
20	20A	20B	20C	20D	20E																																																																																																																																																																																																																																																																																																																																																																																																																																																																																																																																																																																																																			
21	21A	21B	21C	21D	21E																																																																																																																																																																																																																																																																																																																																																																																																																																																																																																																																																																																																																			
22	22A	22B	22C	22D	22E																																																																																																																																																																																																																																																																																																																																																																																																																																																																																																																																																																																																																			
23	23A	23B	23C	23D	23E																																																																																																																																																																																																																																																																																																																																																																																																																																																																																																																																																																																																																			
24	24A	24B	24C	24D	24E																																																																																																																																																																																																																																																																																																																																																																																																																																																																																																																																																																																																																			
25	25A	25B	25C	25D	25E																																																																																																																																																																																																																																																																																																																																																																																																																																																																																																																																																																																																																			
26	26A	26B	26C	26D	26E																																																																																																																																																																																																																																																																																																																																																																																																																																																																																																																																																																																																																			
27	27A	27B	27C	27D	27E																																																																																																																																																																																																																																																																																																																																																																																																																																																																																																																																																																																																																			
28	28A	28B	28C	28D	28E																																																																																																																																																																																																																																																																																																																																																																																																																																																																																																																																																																																																																			
29	29A	29B	29C	29D	29E																																																																																																																																																																																																																																																																																																																																																																																																																																																																																																																																																																																																																			
30	30A	30B	30C	30D	30E																																																																																																																																																																																																																																																																																																																																																																																																																																																																																																																																																																																																																			
31	31A	31B	31C	31D	31E																																																																																																																																																																																																																																																																																																																																																																																																																																																																																																																																																																																																																			
32	32A	32B	32C	32D	32E																																																																																																																																																																																																																																																																																																																																																																																																																																																																																																																																																																																																																			
33	33A	33B	33C	33D	33E																																																																																																																																																																																																																																																																																																																																																																																																																																																																																																																																																																																																																			
34	34A	34B	34C	34D	34E																																																																																																																																																																																																																																																																																																																																																																																																																																																																																																																																																																																																																			
35	35A	35B	35C	35D	35E																																																																																																																																																																																																																																																																																																																																																																																																																																																																																																																																																																																																																			
36	36A	36B	36C	36D	36E																																																																																																																																																																																																																																																																																																																																																																																																																																																																																																																																																																																																																			
37	37A	37B	37C	37D	37E																																																																																																																																																																																																																																																																																																																																																																																																																																																																																																																																																																																																																			
38	38A	38B	38C	38D	38E																																																																																																																																																																																																																																																																																																																																																																																																																																																																																																																																																																																																																			
39	39A	39B	39C	39D	39E																																																																																																																																																																																																																																																																																																																																																																																																																																																																																																																																																																																																																			
40	40A	40B	40C	40D	40E																																																																																																																																																																																																																																																																																																																																																																																																																																																																																																																																																																																																																			
41	41A	41B	41C	41D	41E																																																																																																																																																																																																																																																																																																																																																																																																																																																																																																																																																																																																																			
42	42A	42B	42C	42D	42E																																																																																																																																																																																																																																																																																																																																																																																																																																																																																																																																																																																																																			
43	43A	43B	43C	43D	43E																																																																																																																																																																																																																																																																																																																																																																																																																																																																																																																																																																																																																			
44	44A	44B	44C	44D	44E																																																																																																																																																																																																																																																																																																																																																																																																																																																																																																																																																																																																																			
45	45A	45B	45C	45D	45E																																																																																																																																																																																																																																																																																																																																																																																																																																																																																																																																																																																																																			
46	46A	46B	46C	46D	46E																																																																																																																																																																																																																																																																																																																																																																																																																																																																																																																																																																																																																			
47	47A	47B	47C	47D	47E																																																																																																																																																																																																																																																																																																																																																																																																																																																																																																																																																																																																																			
48	48A	48B	48C	48D	48E																																																																																																																																																																																																																																																																																																																																																																																																																																																																																																																																																																																																																			
49	49A	49B	49C	49D	49E																																																																																																																																																																																																																																																																																																																																																																																																																																																																																																																																																																																																																			
50	50A	50B	50C	50D	50E																																																																																																																																																																																																																																																																																																																																																																																																																																																																																																																																																																																																																			
51	51A	51B	51C	51D	51E																																																																																																																																																																																																																																																																																																																																																																																																																																																																																																																																																																																																																			
52	52A	52B	52C	52D	52E																																																																																																																																																																																																																																																																																																																																																																																																																																																																																																																																																																																																																			
53	53A	53B	53C	53D	53E																																																																																																																																																																																																																																																																																																																																																																																																																																																																																																																																																																																																																			
54	54A	54B	54C	54D	54E																																																																																																																																																																																																																																																																																																																																																																																																																																																																																																																																																																																																																			
55	55A	55B	55C	55D	55E																																																																																																																																																																																																																																																																																																																																																																																																																																																																																																																																																																																																																			
56	56A	56B	56C	56D	56E																																																																																																																																																																																																																																																																																																																																																																																																																																																																																																																																																																																																																			
57	57A	57B	57C	57D	57E																																																																																																																																																																																																																																																																																																																																																																																																																																																																																																																																																																																																																			
58	58A	58B	58C	58D	58E																																																																																																																																																																																																																																																																																																																																																																																																																																																																																																																																																																																																																			
59	59A	59B	59C	59D	59E																																																																																																																																																																																																																																																																																																																																																																																																																																																																																																																																																																																																																			
60	60A	60B	60C	60D	60E																																																																																																																																																																																																																																																																																																																																																																																																																																																																																																																																																																																																																			
61	61A	61B	61C	61D	61E																																																																																																																																																																																																																																																																																																																																																																																																																																																																																																																																																																																																																			
62	62A	62B	62C	62D	62E																																																																																																																																																																																																																																																																																																																																																																																																																																																																																																																																																																																																																			
63	63A	63B	63C	63D	63E																																																																																																																																																																																																																																																																																																																																																																																																																																																																																																																																																																																																																			
64	64A	64B	64C	64D	64E																																																																																																																																																																																																																																																																																																																																																																																																																																																																																																																																																																																																																			
65	65A	65B	65C	65D	65E																																																																																																																																																																																																																																																																																																																																																																																																																																																																																																																																																																																																																			
66	66A	66B	66C	66D	66E																																																																																																																																																																																																																																																																																																																																																																																																																																																																																																																																																																																																																			
67	67A	67B	67C	67D	67E																																																																																																																																																																																																																																																																																																																																																																																																																																																																																																																																																																																																																			
68	68A	68B	68C	68D	68E																																																																																																																																																																																																																																																																																																																																																																																																																																																																																																																																																																																																																			
69	69A	69B	69C	69D	69E																																																																																																																																																																																																																																																																																																																																																																																																																																																																																																																																																																																																																			
70	70A	70B	70C	70D	70E																																																																																																																																																																																																																																																																																																																																																																																																																																																																																																																																																																																																																			
71	71A	71B	71C	71D	71E																																																																																																																																																																																																																																																																																																																																																																																																																																																																																																																																																																																																																			
72	72A	72B	72C	72D	72E																																																																																																																																																																																																																																																																																																																																																																																																																																																																																																																																																																																																																			
73	73A	73B	73C	73D	73E																																																																																																																																																																																																																																																																																																																																																																																																																																																																																																																																																																																																																			
74	74A	74B	74C	74D	74E																																																																																																																																																																																																																																																																																																																																																																																																																																																																																																																																																																																																																			
75	75A	75B	75C	75D	75E																																																																																																																																																																																																																																																																																																																																																																																																																																																																																																																																																																																																																			
76	76A	76B	76C	76D	76E																																																																																																																																																																																																																																																																																																																																																																																																																																																																																																																																																																																																																			
77	77A	77B	77C	77D	77E																																																																																																																																																																																																																																																																																																																																																																																																																																																																																																																																																																																																																			
78	78A	78B	78C	78D	78E																																																																																																																																																																																																																																																																																																																																																																																																																																																																																																																																																																																																																			
79	79A	79B	79C	79D	79E																																																																																																																																																																																																																																																																																																																																																																																																																																																																																																																																																																																																																			
80	80A	80B	80C	80D	80E																																																																																																																																																																																																																																																																																																																																																																																																																																																																																																																																																																																																																			
81	81A	81B	81C	81D	81E																																																																																																																																																																																																																																																																																																																																																																																																																																																																																																																																																																																																																			
82	82A	82B	82C	82D	82E																																																																																																																																																																																																																																																																																																																																																																																																																																																																																																																																																																																																																			
83	83A	83B	83C	83D	83E																																																																																																																																																																																																																																																																																																																																																																																																																																																																																																																																																																																																																			
84	84A	84B	84C	84D	84E																																																																																																																																																																																																																																																																																																																																																																																																																																																																																																																																																																																																																			
85	85A	85B	85C	85D	85E																																																																																																																																																																																																																																																																																																																																																																																																																																																																																																																																																																																																																			
86	86A	86B	86C	86D	86E																																																																																																																																																																																																																																																																																																																																																																																																																																																																																																																																																																																																																			
87	87A	87B	87C	87D	87E																																																																																																																																																																																																																																																																																																																																																																																																																																																																																																																																																																																																																			
88	88A	88B	88C	88D	88E																																																																																																																																																																																																																																																																																																																																																																																																																																																																																																																																																																																																																			
89	89A	89B	89C	89D	89E																																																																																																																																																																																																																																																																																																																																																																																																																																																																																																																																																																																																																			
90	90A	90B	90C	90D	90E																																																																																																																																																																																																																																																																																																																																																																																																																																																																																																																																																																																																																			
91	91A	91B	91C	91D	91E																																																																																																																																																																																																																																																																																																																																																																																																																																																																																																																																																																																																																			
92	92A	92B	92C	92D	92E																																																																																																																																																																																																																																																																																																																																																																																																																																																																																																																																																																																																																			
93	93A	93B	93C	93D	93E																																																																																																																																																																																																																																																																																																																																																																																																																																																																																																																																																																																																																			
94	94A	94B	94C	94D	94E																																																																																																																																																																																																																																																																																																																																																																																																																																																																																																																																																																																																																			
95	95A	95B	95C	95D	95E																																																																																																																																																																																																																																																																																																																																																																																																																																																																																																																																																																																																																			
96	96A	96B	96C	96D	96E																																																																																																																																																																																																																																																																																																																																																																																																																																																																																																																																																																																																																			
97	97A	97B	97C	97D	97E																																																																																																																																																																																																																																																																																																																																																																																																																																																																																																																																																																																																																			
98	98A	98B	98C	98D	98E																																																																																																																																																																																																																																																																																																																																																																																																																																																																																																																																																																																																																			
99	99A	99B	99C	99D	99E																																																																																																																																																																																																																																																																																																																																																																																																																																																																																																																																																																																																																			
100	100A	100B	100C	100D	100E																																																																																																																																																																																																																																																																																																																																																																																																																																																																																																																																																																																																																			

母线KSL101ARC (H型)装置尺寸图

注：下图中尺寸单位均为mm。

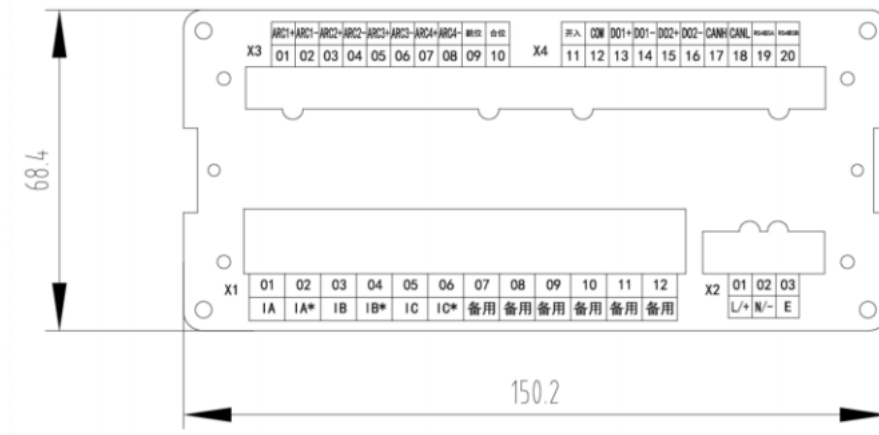

端子示意图

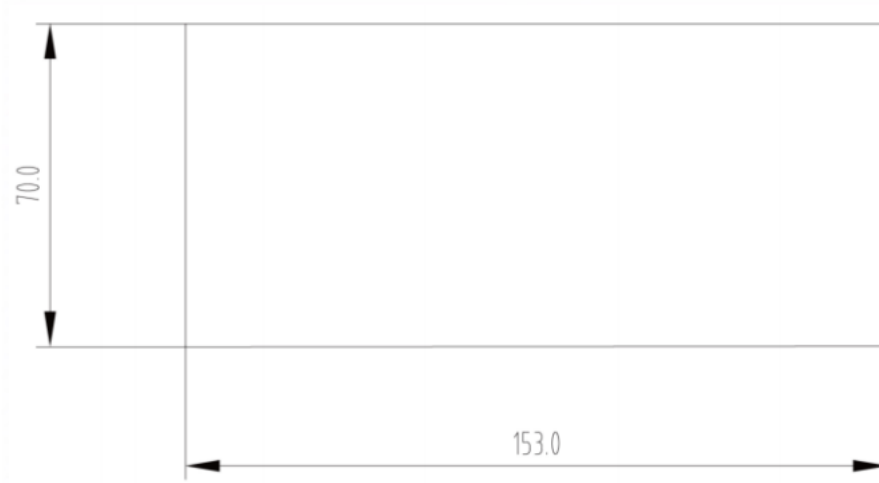

开孔尺寸图

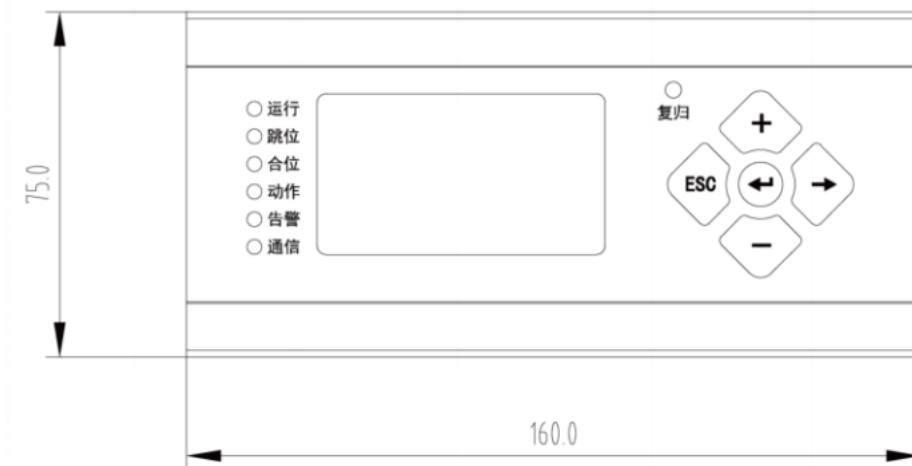

外形尺寸图

馈线KSL101ARC (F型) 尺寸图

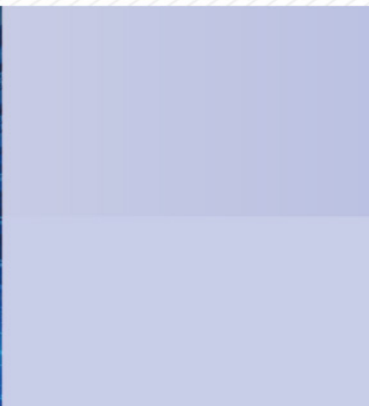

克斯勒电气

Tel: 025-57061666

Fax: 025-57061667

<http://www.ksl-electric.com>

Address: 中国·南京市江宁区水阁路6号38栋